

# The Capitol Automatic Music Co.

- Two Men and the **Sweet Sixteen** -

The Capitol Automatic Music Co., originally named The Capitol Piano and Organ Co., was founded and incorporated around 1920 as a 51% owned subsidiary of the North Tonawanda Musical Instrument Works and 49% owned by William A. Goetz and Samuel Kresberg from New York. The defunct musical instrument works in North Tonawanda was originally founded by a group of employees from the DeKleist factory a few years before it was acquired by Wurlitzer in 1909, but the management of the works failed to profit from war work when the United States entered WW1 in 1917, and the Rand Company Inc. headed by James H. Rand Sr. bought the capital stock of the company in 1918. In this way the instrument works became the Musical Instrument Division of the Rand Company Inc., and continued to manufacture automatic musical instruments until around 1925.

The other owners of the subsidiary, William A. Goetz and Samuel Kresberg, were aggressive salesmen and former representatives for Wurlitzer in New York City, and The Capitol Automatic Music Co. was formed as a well managed selling effort in the City. In fact, William A. Goetz was manager of the automatic division of the Rudolph Wurlitzer Co. at 119 West 40th Street in New York for more than five years, and successfully operating Tonophone player pianos on routes. In this way William A. Goetz got into contact with Samuel Kresberg, a young man working for John J. Monks, who delivered mainly coin-op pianos to restaurants and other locations around the City of New York. The new company, The Capitol Piano and Organ Co., mainly operated coin-op Pianolin instruments, a 44-note piano accompanied by violin and flute pipes, but the new company named the instrument Midget Orchestra, and the aggressive sales methods did result in good earnings. The Capitol company also rather successfully operated keyboard type pianos on the routes around New York, and the company also managed the nationwide distribution of all automatic musical instruments from the North Tonawanda Musical Instrument Works. When the Rand Company Inc. finally gave up the production of music instruments in 1925, William A. Goetz and Samuel Kresberg gained control of the entire music business of The Capitol Piano and Organ Co., and the company was active in operating coin-op pianos and orchestrions until around 1929, when the financial crisis following the Wall Street crash killed most of the automatic music instrument industry.

In the autumn 1929 Samuel Kresberg again contacted William A. Goetz, who was still active and holder of the Capitol company name, and together they adapted to the new order of things and started operating coin-op phonographs on previous routes. They were still as aggressive as before in their management and sales methods, and soon the company, now renamed The Capitol Automatic Music Co., turned out to be quite profitable. Samuel Kresberg claimed that the company operated about 2,000

phonographs in the metropolitan area of New York at some time before 1933. It seems that most of these phonographs were cut-down Gabel's Entertainer models. Interesting concerning the last few years of the twenties is also to note that William A. Goetz and Samuel Kresberg filed a patent together for a record control mechanism for automatic phonographs in March 1927.

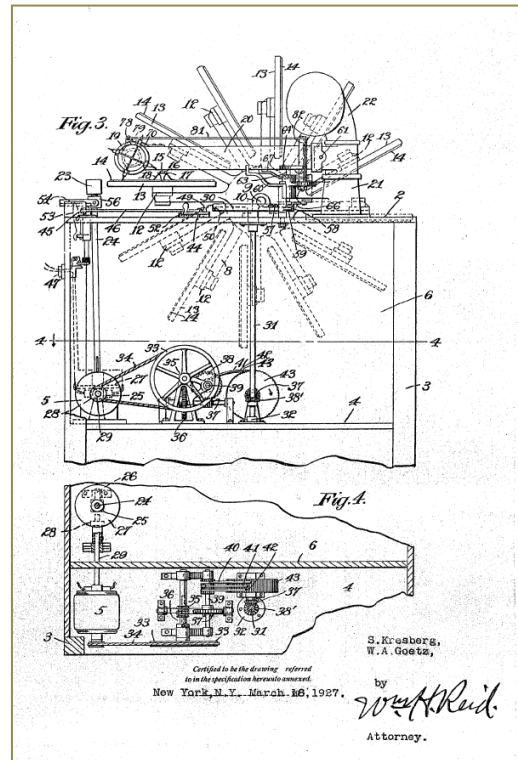

Patent by W. A. Goetz and S. Kresberg, 18th March 1927



12 sel. Capitol "Broadcast Entertainer" introduced 1928

Then, in 1934 Samuel Kresberg and the Italian born Victor F. Peterfesa, a former employee at the Wurlitzer piano factory, developed and patented a new 16-selection mechanism for an automatic coin-operated phonograph, and The Capitol Automatic Music Co. took care of the sales to other operators and of course the operation on its own routes in the City. Samuel Kresberg explained to the trade that they wanted sixteen selections based on their own long-time experience, because ten records were insufficient since they did not promote enough variety, and twenty records in a revamped, cut-down instrument were too many as only fifteen or sixteen were ever used. The new mechanism looked like the 12-selection Junior changer used in the Gabel models, but it seems there were no patent disputes between the two companies and former business partners. To promote the new coin-op model The Capitol Automatic Music Co. even built a modern style bar in the showroom at 460 West 34th Street, the new facilities only a few blocks from the offices at 331 West 34th Street that previously also housed the showrooms of The Capitol Piano and Organ Co.. The company still had access to the old instrument works in North Tonawanda for cabinet making, and it seems that only the final assembly took place at the new facilities. At the time the former main supplier of phonographs, The John Gabel Manufacturing Co., had established its own showroom and offices at 351 West 14th Street.

In the year 1935 The Capitol Automatic Music Co. no longer manufactured its own phonographs, but started to distribute the new Rock-Ola phonograph line on its routes, and in 1938 the company, by then the largest operator on the East Coast, distributed the phonograph line of the J. P. Seeburg Corp. in New York until the outbreak of WW2. It seems that around 1941/42 Samuel Kresberg was still on the eternal quest of foreseeing the next trend, and he joined the U. S. Challenge Co. in Chicago to become manager of the division at Batavia Metal Products Co. making the Filben mechanisms for the stow-a-way units connected to the music library systems. In October 1945 the Challenge Industries, which was meant to be a sales division of the U. S. Challenge Co. was set up by Samuel Kresberg and Albert M. Cole, but it never really got off the ground. Due to some disagreements Kresberg and Cole decided to leave the company, and they moved back to New York to form the Automatic Products Co. within the soft-drink vending trade. Albert M. Cole was in the vending business before he came to the U. S. Challenge Co., and together with the energetic partner Samuel Kresberg the company was in good hands. The company was later known as Apco Inc. headed by Kresberg. In the mid or maybe late fifties Samuel Kresberg moved to the more agreeable climate in Miami in Florida, and it seems his brother Benjamin Kresberg already lived there. Unfortunately, it has been difficult to find information about Samuel Kresberg's life after he left the phonograph and vending business, but this is only a matter of continued research.

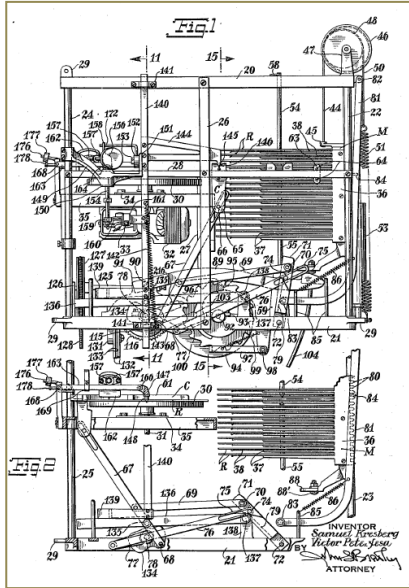

Patent by S. Kresberg and V. Peterfesa, 7th August 1934

William A. Goetz, however, still continued as head of The Capitol Automatic Music Co. to operate coin-op phonographs on routes in New York during and after the war years until he died on the 20th May 1950 after more than thirty years in the business. William A. Goetz was also for many years director of the American Music Operators Association (AMOA). The widow Helen Goetz took over the management of The Capitol Automatic Music Co. assisted by the new manager Al Claire, and they decided to move the main offices of the company to the newer facilities at 460 West 34th Street, but the story of the two business associates, William Anthony Goetz and Samuel Kresberg, who manufactured and operated the Sweet Sixteen phonograph in the mid thirties had come to an end.

\* \* \* \* \*

Gert Almind, 10-04-2010





**Rock-Ola's Largest  
DISTRIBUTOR  
CLOSES OUT  
GABEL LINE**

24 Record Selective  
**PHONOGRAPH**  
Freshly refinished. Perfect  
working condition.

**\$65.00**

**1-YEAR GUARANTEE**  
We will replace any me-  
chanical part that proves  
defective within one year.  
1/3 Deposit, Balance COD.

Ad of 1936  
**CAPITOL AUTOMATIC MUSIC CO., Inc.**  
460 West 34th Street Phone: Medallion 3-5090 New York, N. Y.



Sweet Sixteen